

mowi

Kinestetický dizajn - Interiérový sedací element

ÚSTAV DIZAJNU / INSTITUTE OF DESIGN - 1_BP_D BAKALÁRSKA PRÁCA

Téma / Topic: **Kinestetický dizajn - Interiérový sedací element**

Pedagóg / Pedagogue: Mgr. art. Martin Baláž, ArtD.

Konzultant / Consultant: Mgr. art. Mária Šimková, ArtD.

Študent / Student: **Michaela Tomová**

Akademický rok / Academic year: 2020/2021

Ročník / Class: IV.



**SLOVENSKÁ TECHNICKÁ
UNIVERZITA V BRATISLAVE**
FAKULTA ARCHITEKTÚRY A DIZAJNU

kinestetický dizajn

interiérový sedací element

Aktuálne nášmu vnímaniu dominujú vizuálne a auditívne systémy vnímania, ktorých kvalita ale závisí od kinestetického systému. Od ich spoločnej integrácie následne závisia ďalšie funkcie ako napríklad reč, koordinácia, emocionalita, aktivita alebo pozornosť.

Kinestetický dizajn: 1. vyvolávajúci kinestetický pocit, pohybový pocit, vzťahujúci sa k vnímaniu pohybu, vyvolávajúci pohybovú reakciu, pohyb v priestore a čase, 2. vyžadujúci pohyb/poziciovanie tela pre vnímanie a spracovanie novej informácie z prostredia a následne konanie z nej vyplývajúce, 3. pri ktorom je pohybujúce sa/poziciované telo v časopriestore základom utvárania priestoru, aby vedomie mohlo mať skúsenosť priestorovosti.

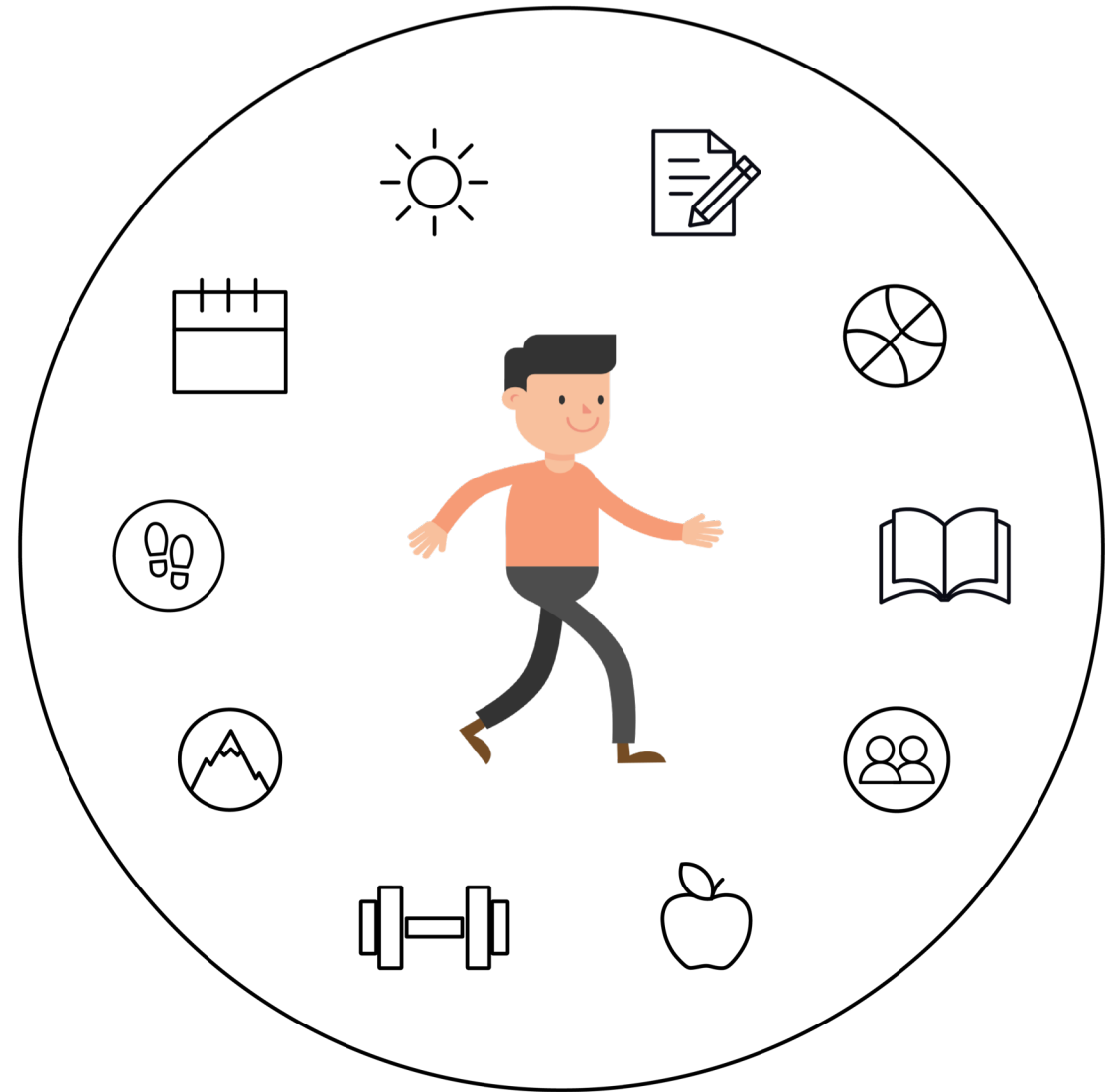

sedavá kultúra

cieľová skupina

Človek sa už nemusí obávať fyzicky ťažkej roboty a tiež dennodenných ťažkostí, ktoré sa spájajú s napĺňaním hlavných existenciálnych potrieb, vďaka rozvoju techniky, elektronizácie a automatizácie. Náplň práce a pracovnej aktivity sa veľakrát nekompromisne pozmeňuje. Za krátky čas prichod moderných technológií spôsobil problémy vo všetkých odvetviach dnešnej spoločnosti, školstvo nevynímajúc. Vplyvom technológií dochádza k čoraz rýchlejšiemu tempu premien a podobám skutočného života, oveľa viac, než by sme si priali.



experiment a pozorovanie

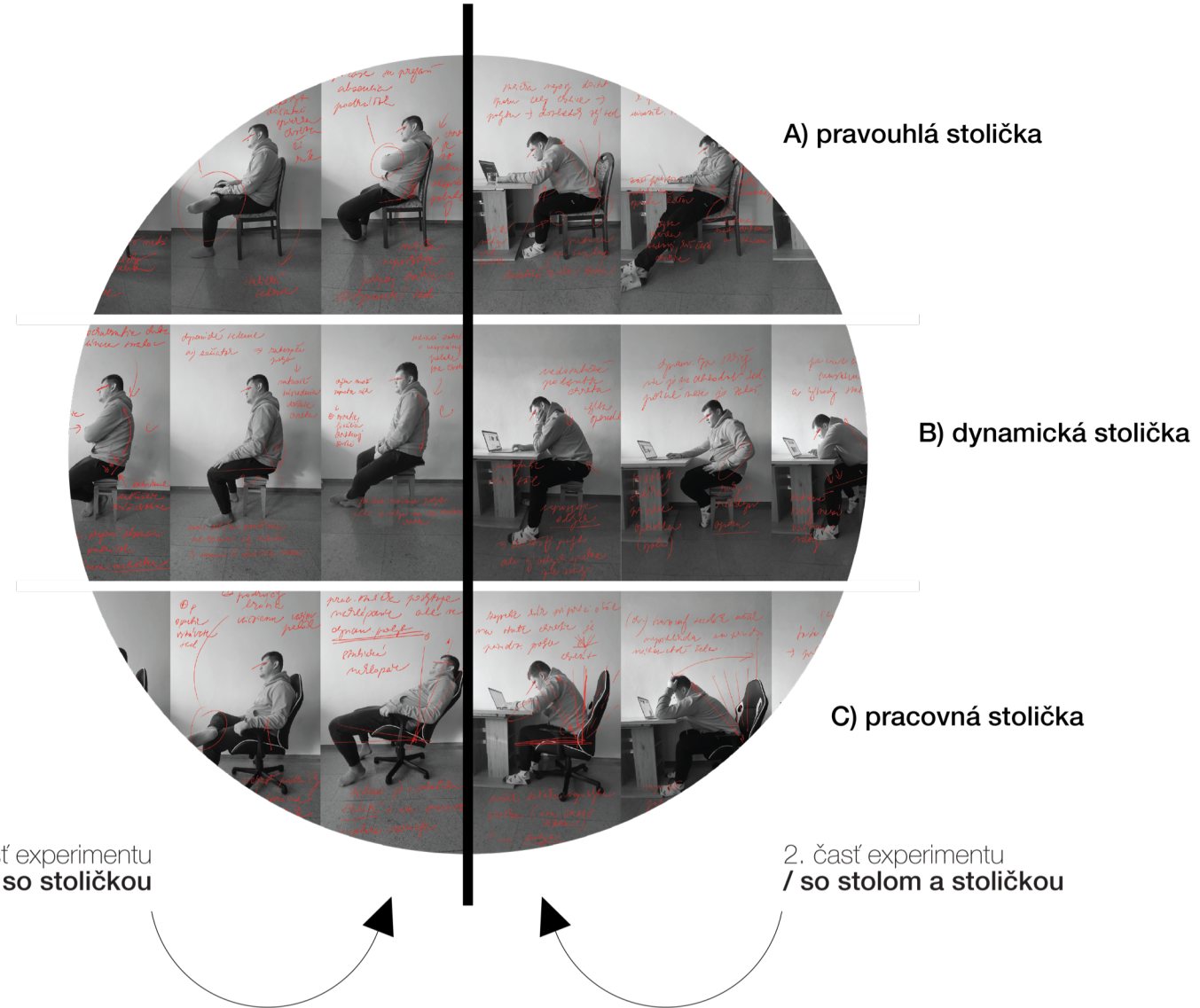

proces navrhovania

prvá fáza

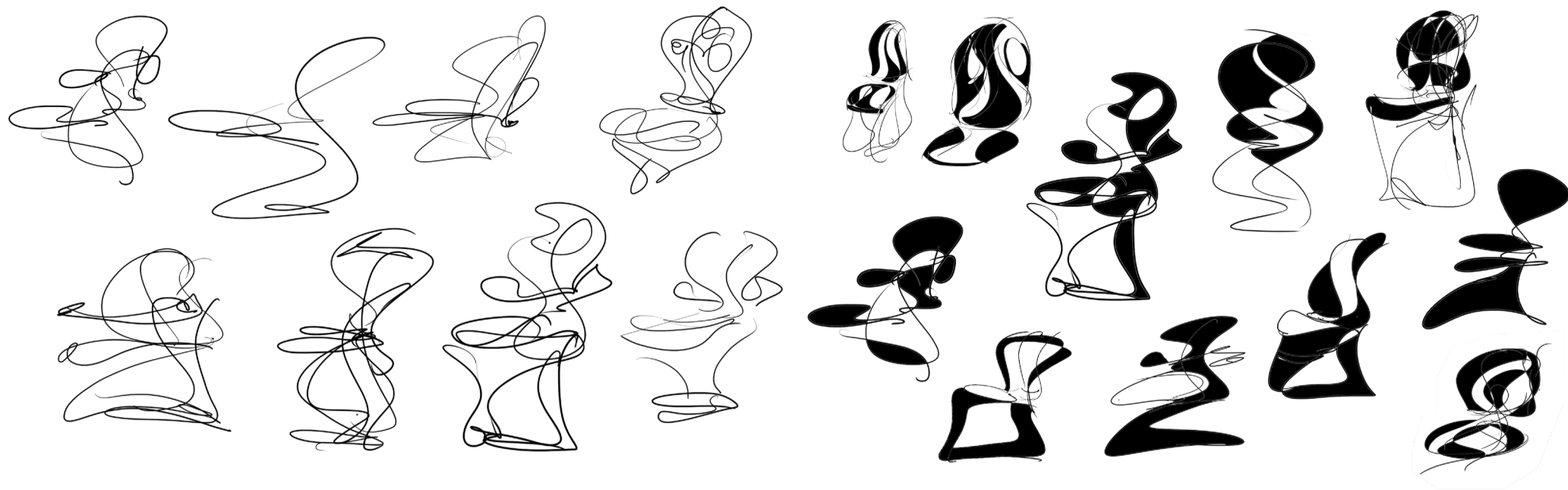

proces navrhovania

druhá fáza

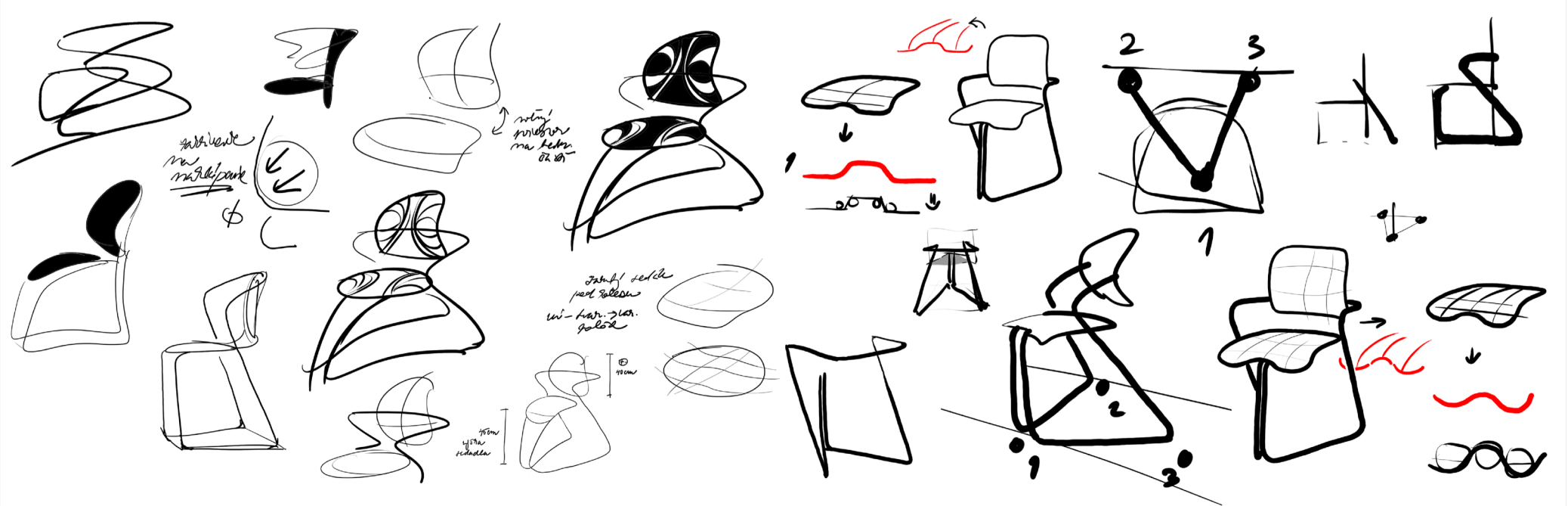

proces navrhovania

tretia fáza

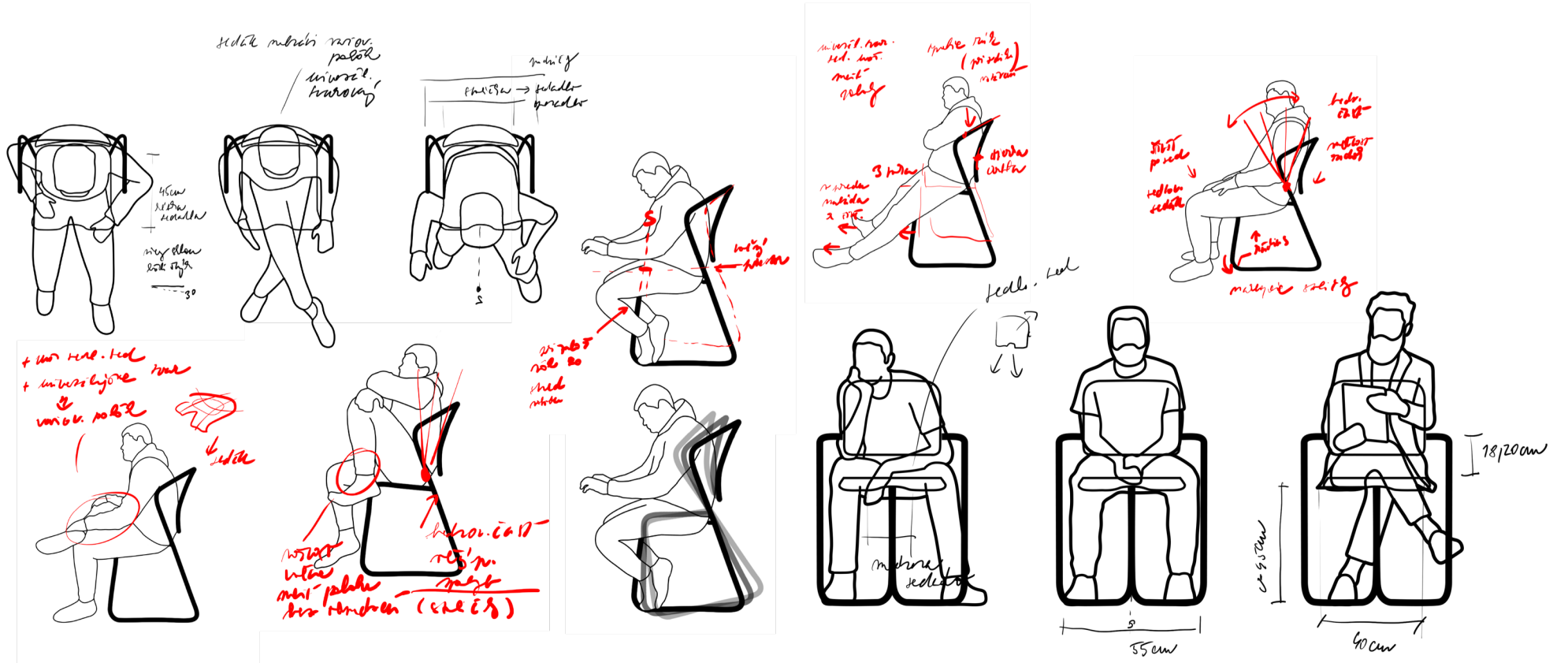

proces navrhovania
štvrtá fáza



pracovný model

overovanie tvarov, rozmerov



1.



2.



3.



4.

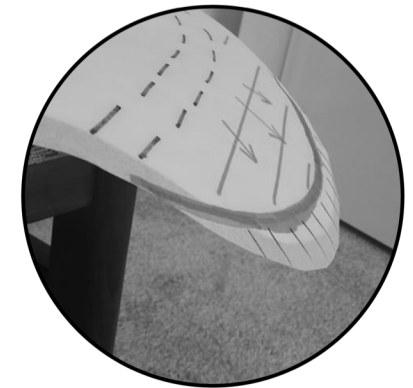

5.

pôvodný tvar konštrukcie
pod sedadlom

zmena tvaru konštrukcie
a prednej časti sedadla

funkčnosť a ergonómia stoličky



naklápanie stoličky v koncepte mowi

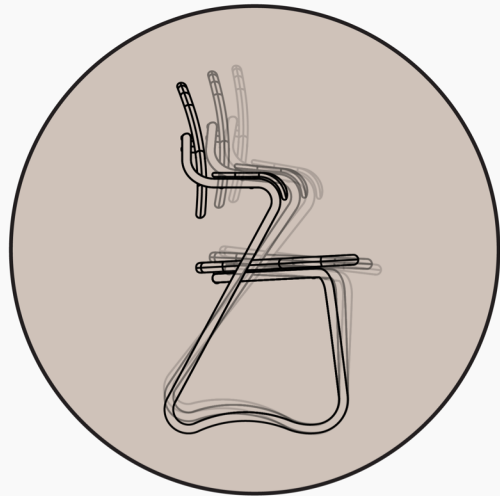

naklápanie



variant fixácie stoličky

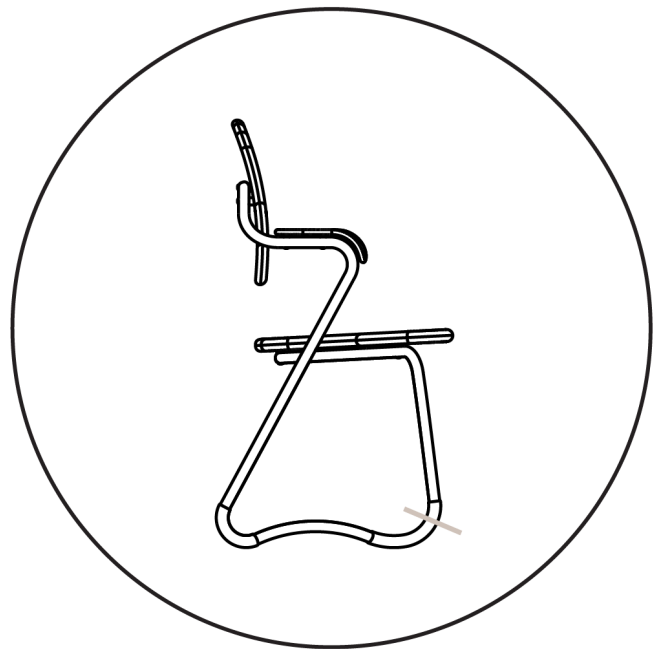

zarážka

porovnanie polôh pri sedení

na pravouhlej stoličke vs. v koncepte mowi

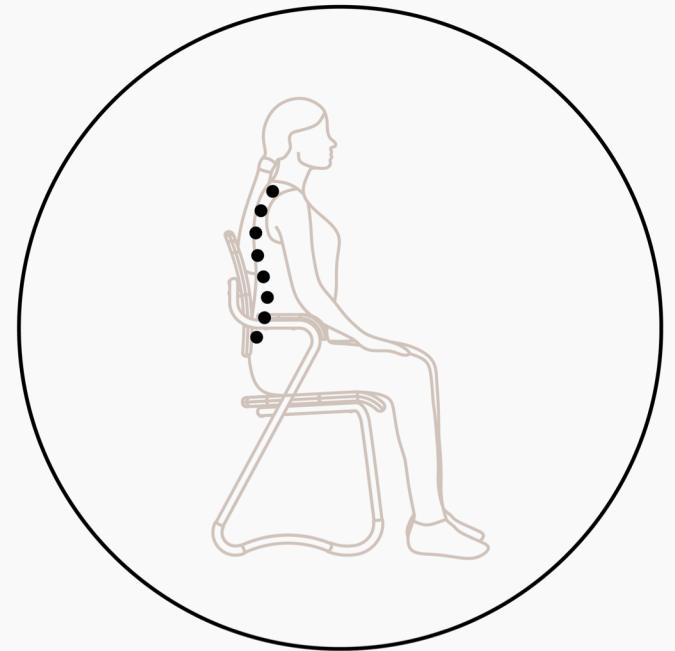
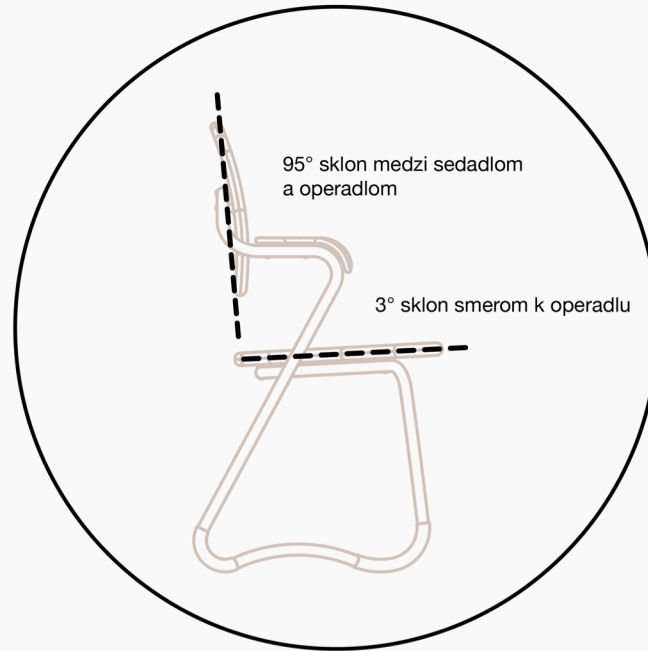

stolička mowi

so stolom

Stôl v koncepte mowi bol
navrhnutý na ilustráciu
rozmerov stoličky

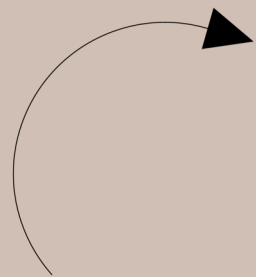

porovnanie rozmerov stoličky s rozmermi stola

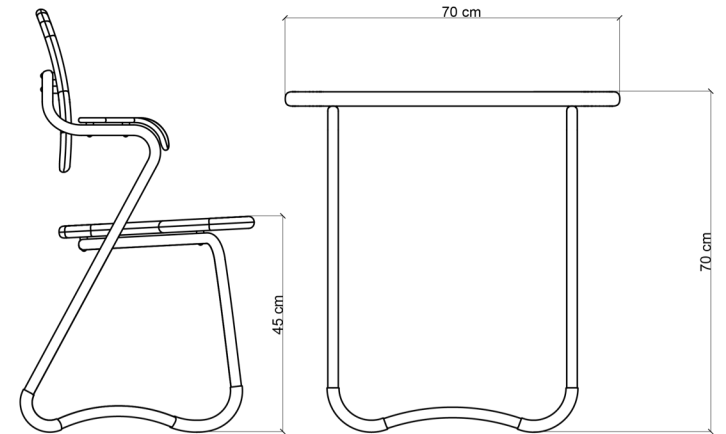
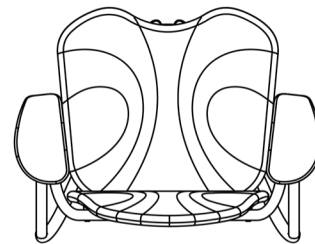
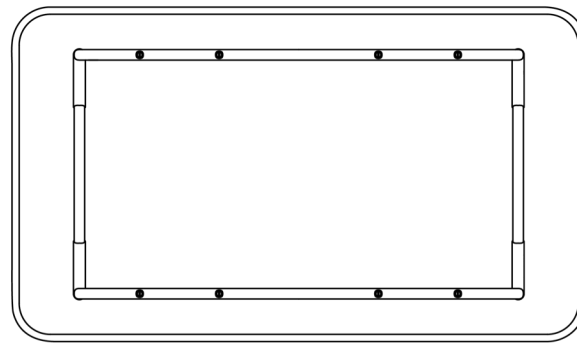
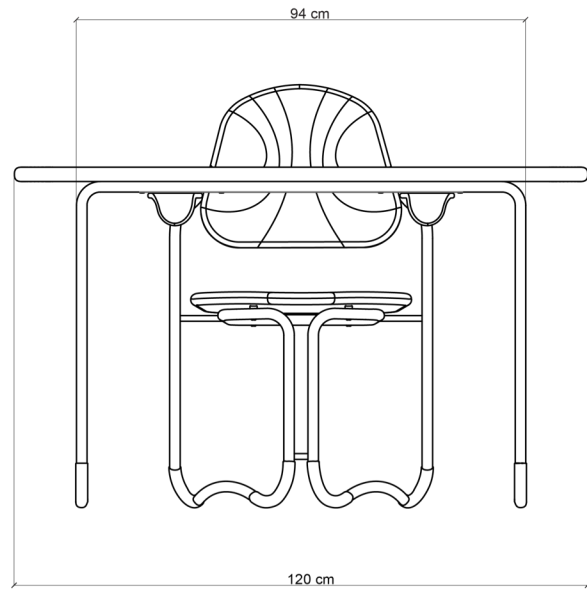

stolička mowi
so stolom

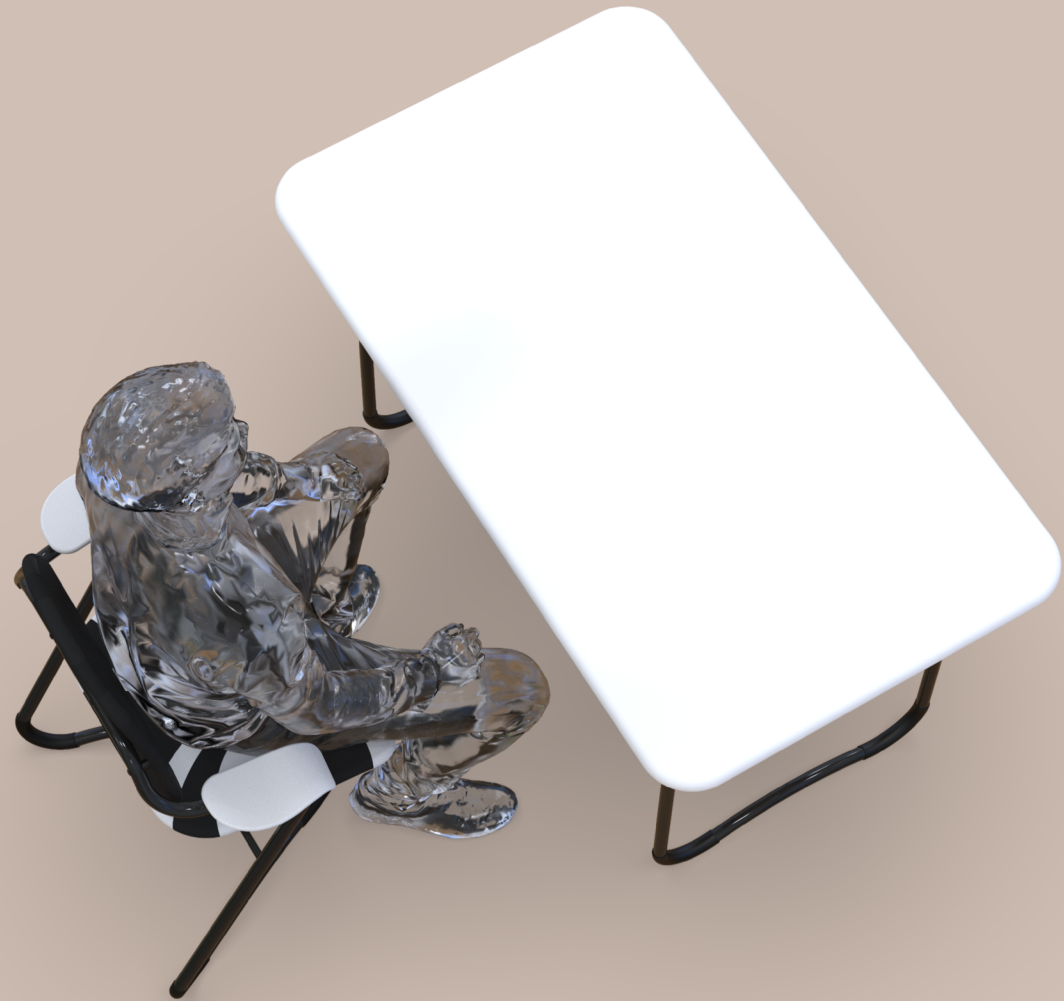

stolička mowi
so stolom



história ako zdroj inšpirácie

prelom storočí

kreslo Wassily
Marcel Breuer



technologické riešenie stoličky

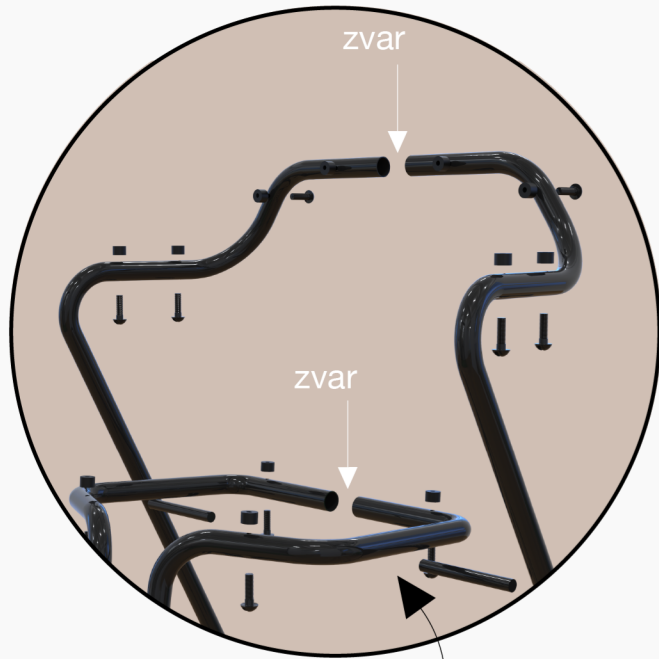

prizvarenie kotviacich prvkov

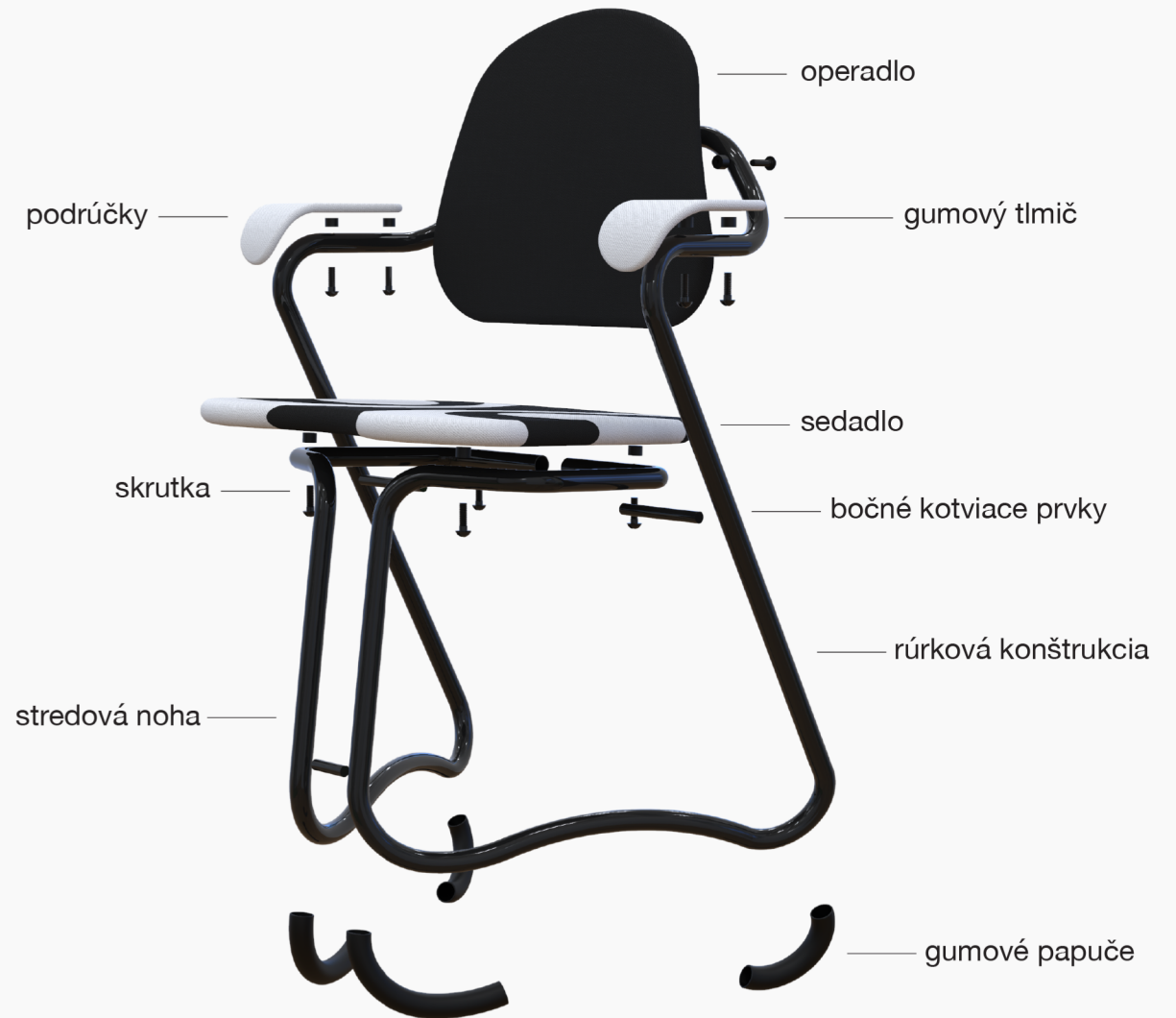

výrobný proces

stoličky mowi

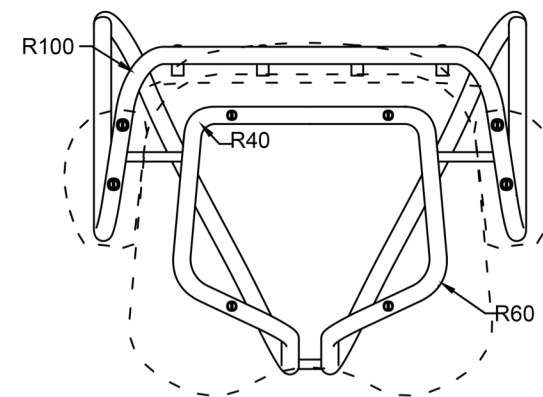
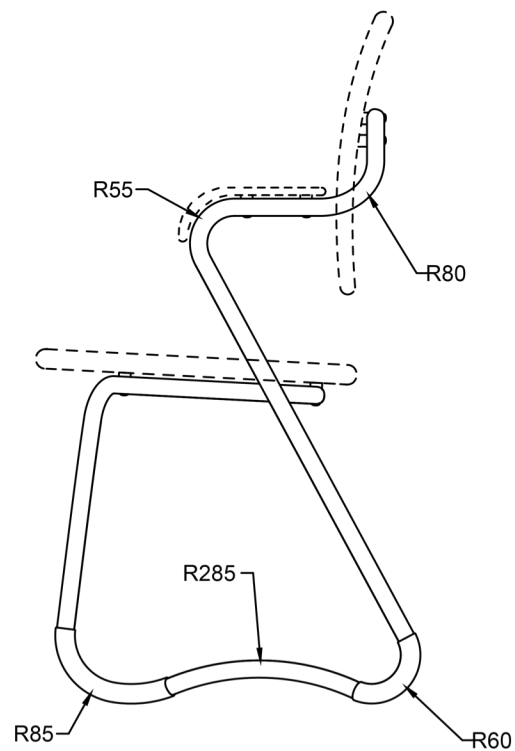
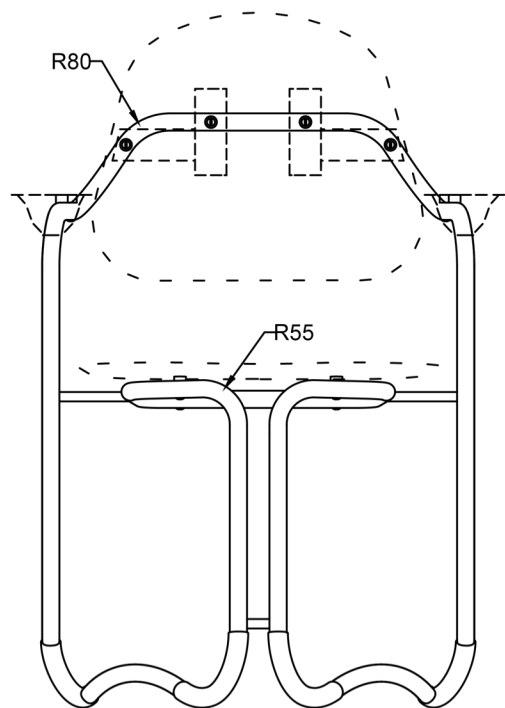

detail kotvenia stoličky

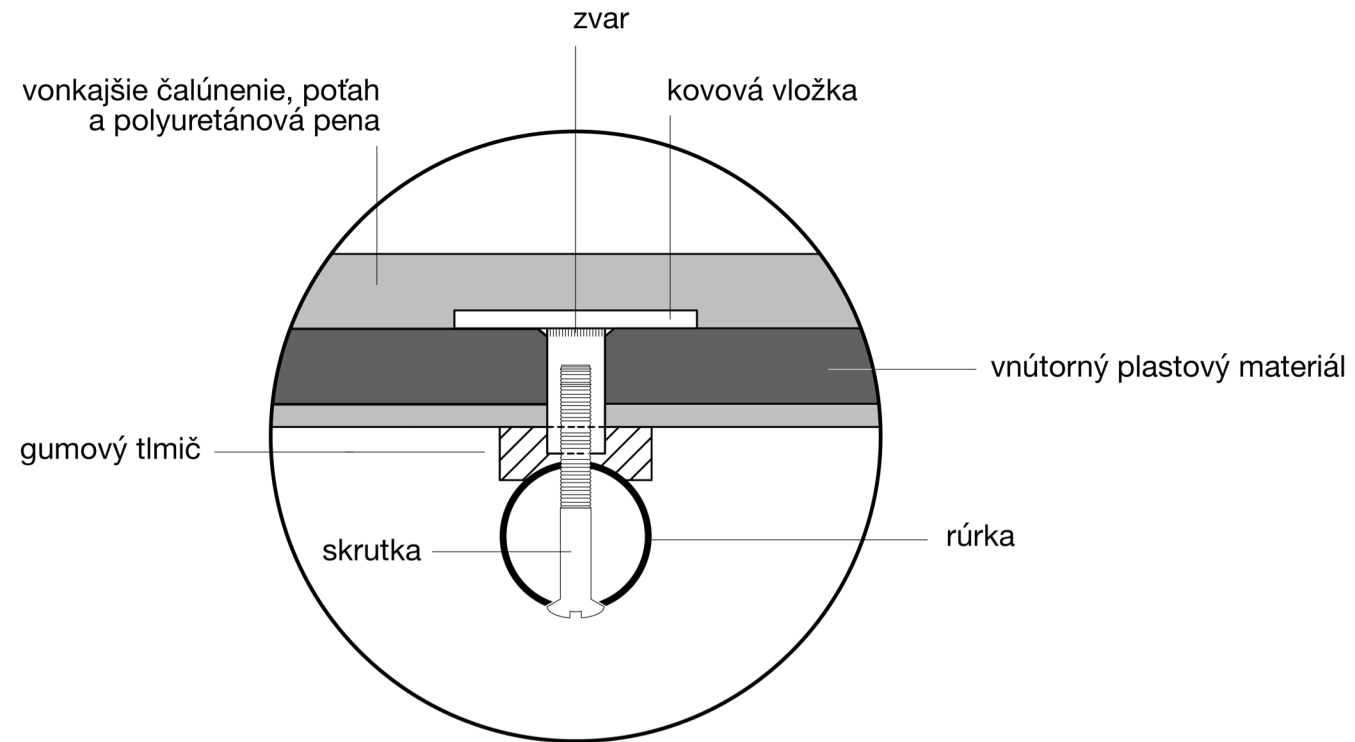

detaily sedacieho prvku konceptu mowi

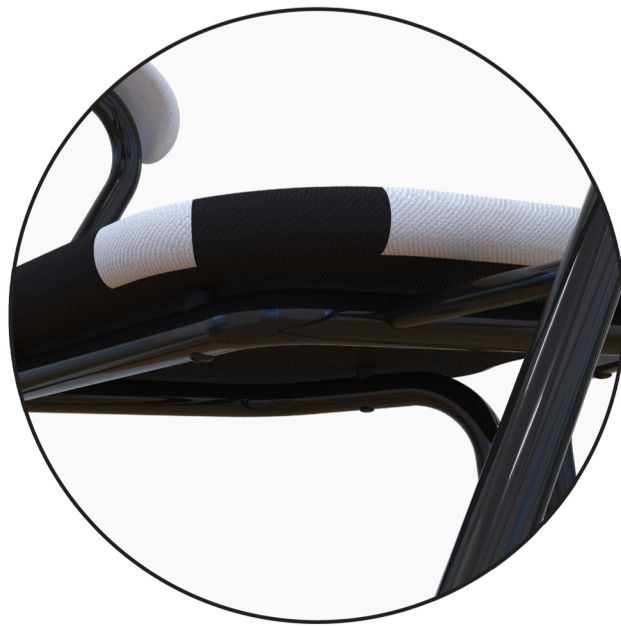
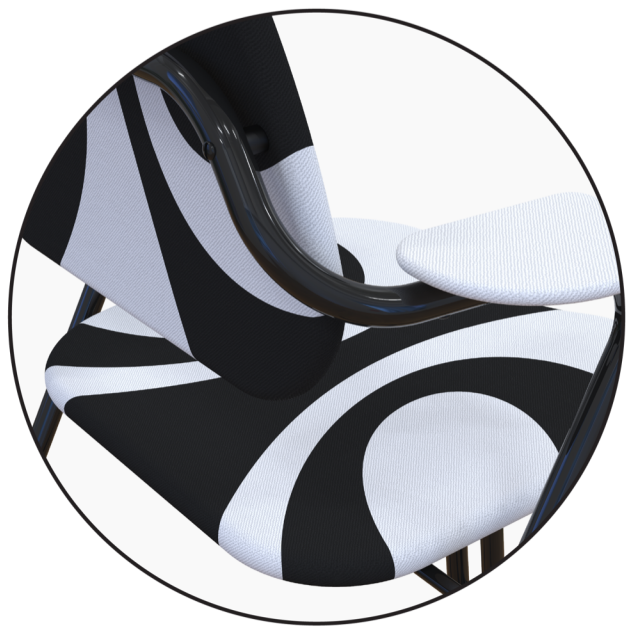

materiálové riešenie stoličky



sedadlo, operadlo, područky
potahová látka



operadlo
PP



konštrukcia stoličky
ocel'

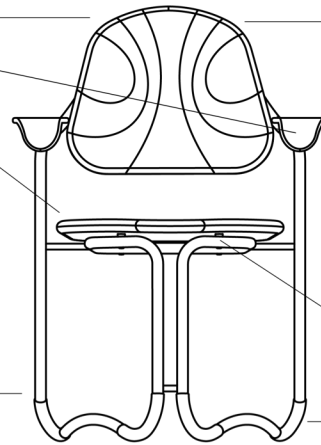

tlmiče, papuče
guma

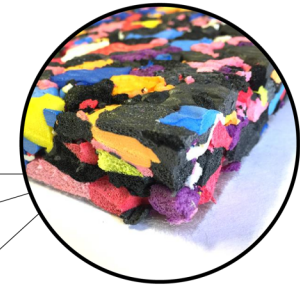
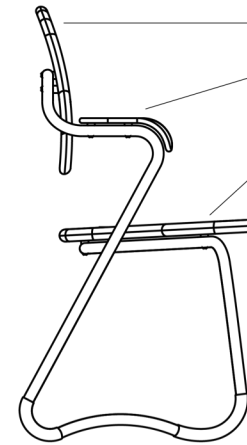

sedadlo, operadlo, područky
PUR pena



sedadlo
**DuPont / Hytrel
TPC-ET**

ohyb materiálu sedadla

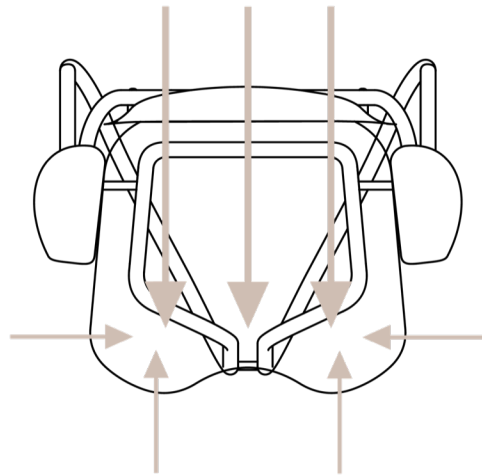

1.

pôsobenie sily na materiál
sedadla / záťaž človeka

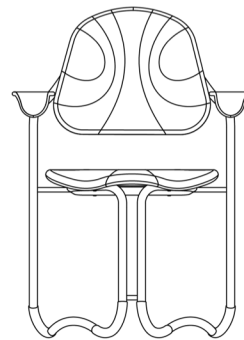
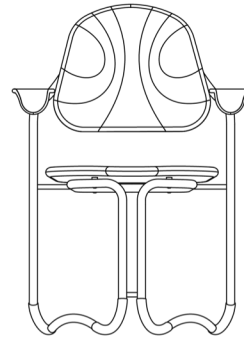

1.



2.

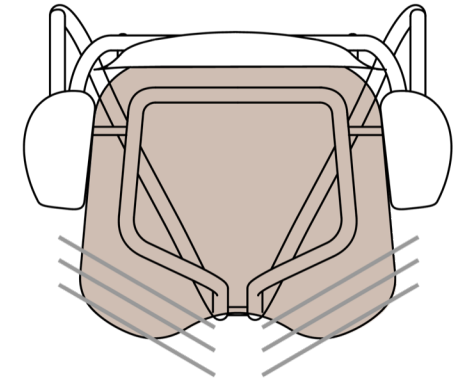

2.

prispôsobenie / ohyb
materiálu sedadla
v dôsledku záťaže človeka

detail ohybu materiálu sedadla

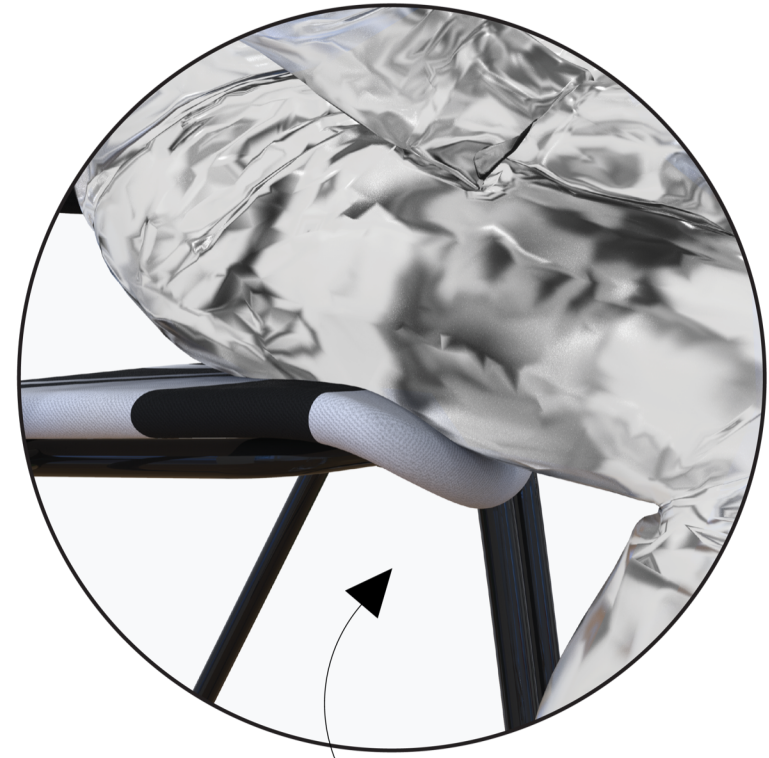
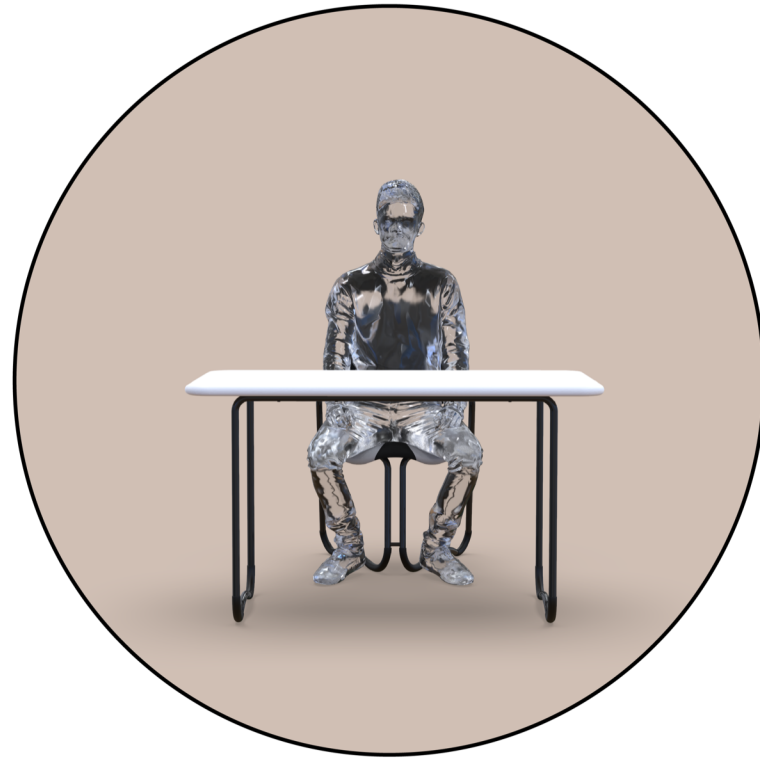

ohyb materiálu
sedadla

vzor na čalúnení

funkcia

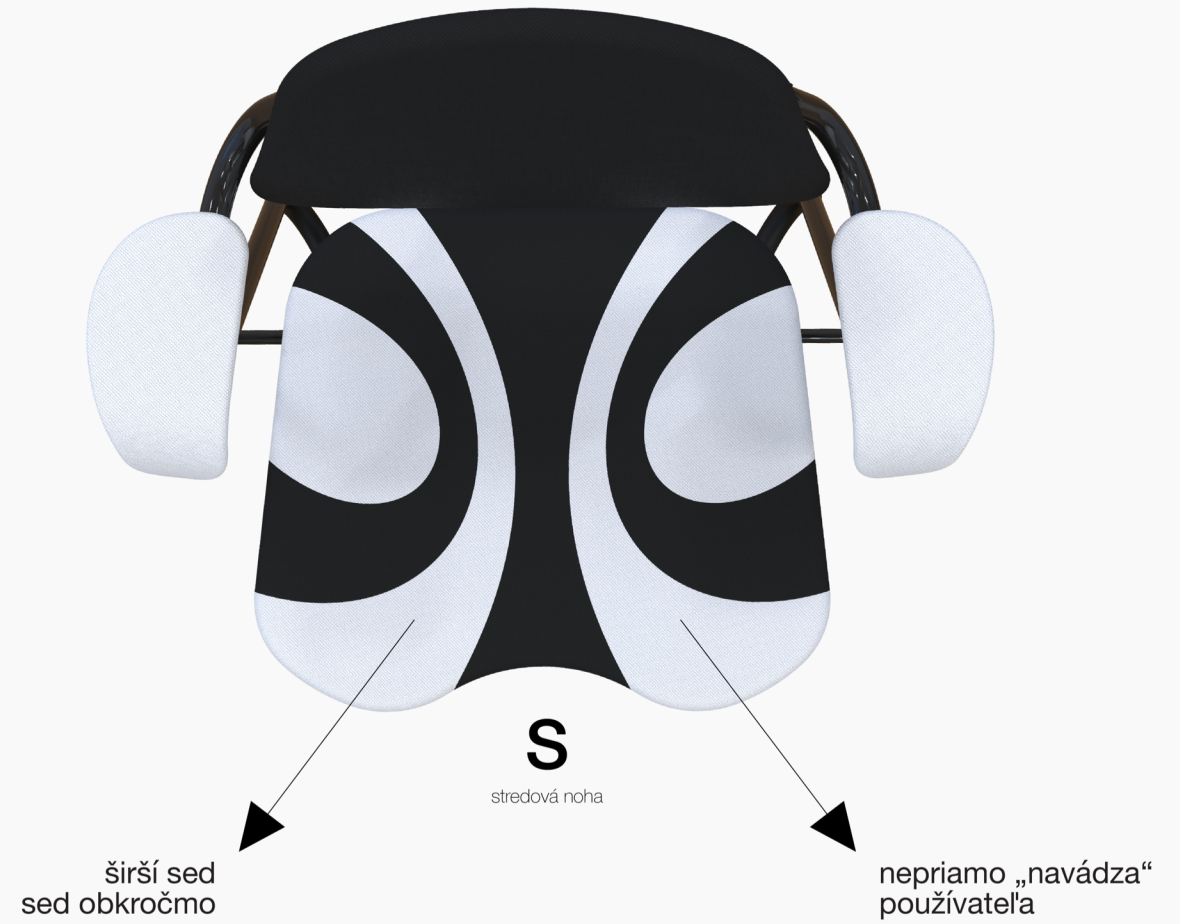
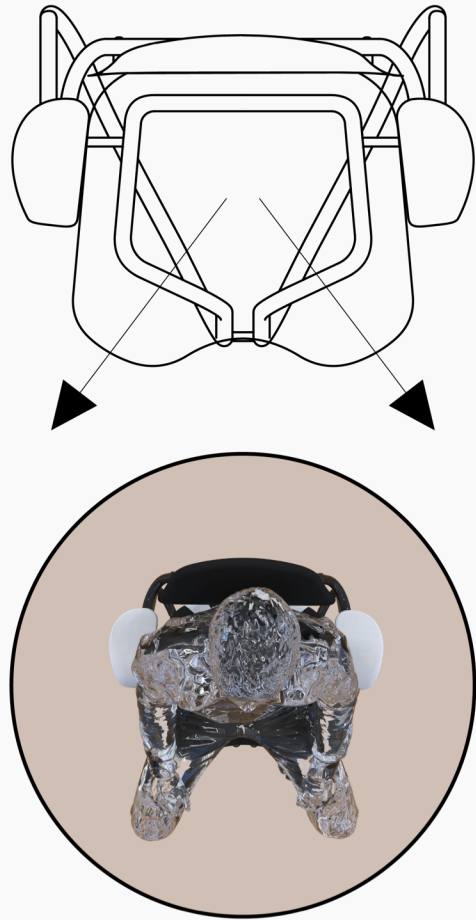

farebné varianty

stoličky mowi



tvárové varianty stoličky mowi

stolička mowi
s podrúčkami



stolička mowi
bez podrúčok



finálne rozmery

stoličky mowi

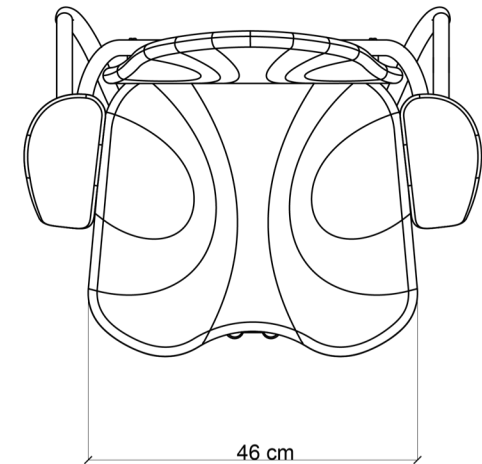
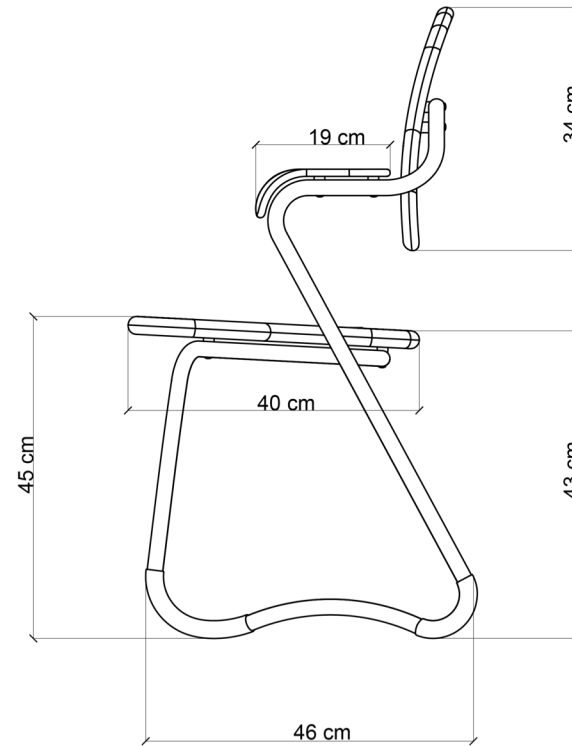
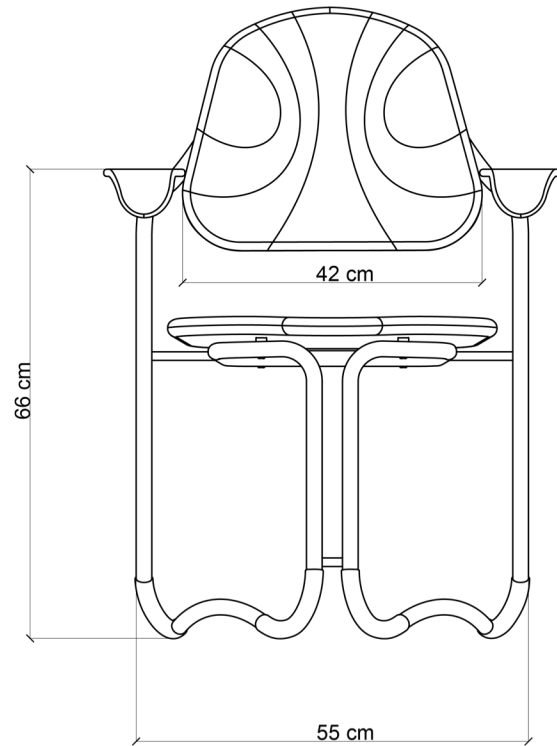

finálny koncept

mowi



stolička k pracovnému stolu



finálny koncept

mowi



finálny koncept
mowi



finálny koncept
mowi



d'akujem
za pozornost'

